

• SPECIFICATION •

• 4292 - IO TWO HOLE SINK MIXER C SPOUT WITH CROSSHEAD HANDLES

- Handcrafted in the UK
- 1/4 turn ceramic disc flow control
- Vernier insert for accurate handle alignment
- Unique handle construction with integral bearing ring
- Single flow spout
- Fitted with 15mm check valves
- Ideally installed in equal pressure systems

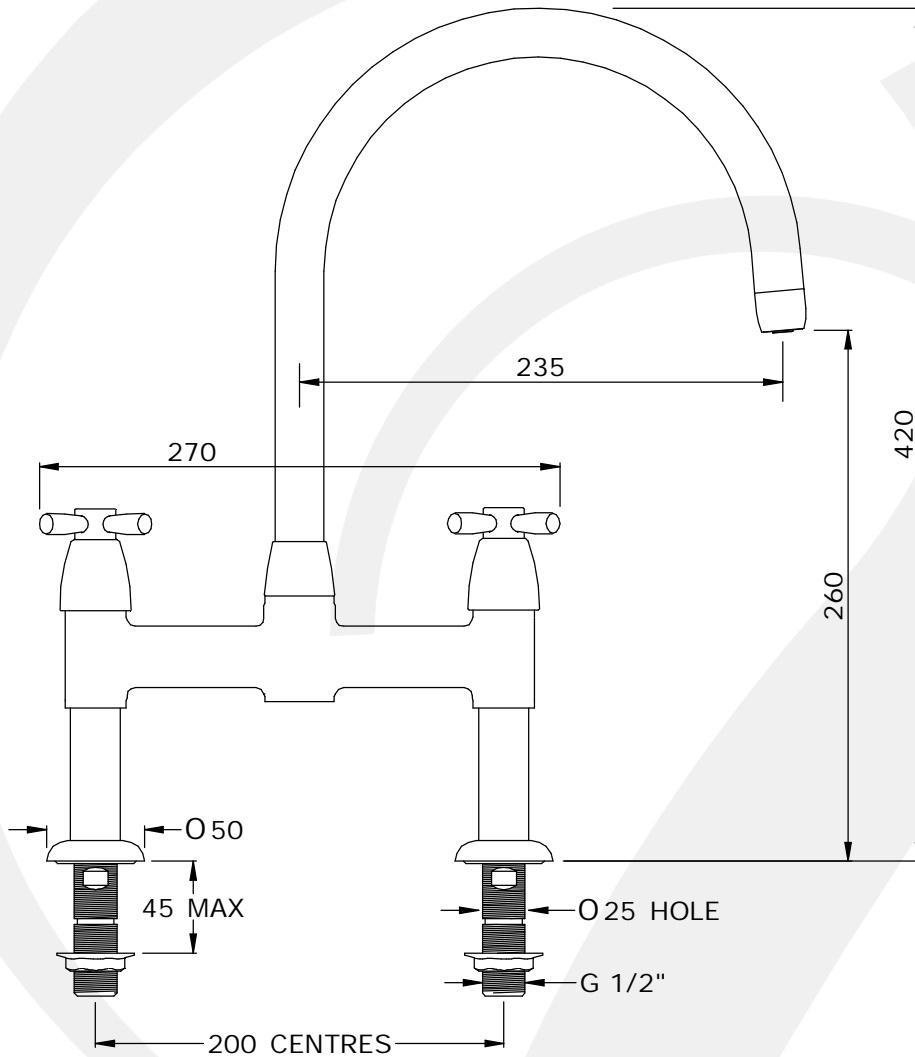

ALL UNITS IN mm
UNLESS OTHERWISE
STATED

Available Finishes:

- Chrome
- Nickel
- Pewter
- Polished Brass
- Satin Brass
- Aged Brass
- Gold
- English Bronze

• Temp Range:
Min 1°C / 34°F
Max 70°C / 158°F

• Recommended
Working Pressure:
Min 1bar / 15psi
Max 5bar / 75psi

• Packed Weight:
3.3 kg

Available Options:

- 5.7L/min regulated spout (Prefix AR.)
- Rinse version
- Matching soap dispenser

Flow Rates:

- 1 Bar: 18.6 L/Min
- 2 Bar: 21.2 L/Min
- 3 Bar: 21.2 L/Min